

Operating Instructions

CENTER DRIVING UNIT **GX Ultimate**

Motor Unit

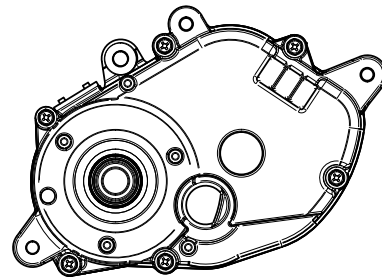
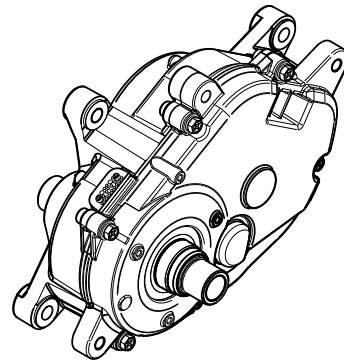

- Before operating this product, please read the instructions carefully and save this manual for future use.
- Before using this product, be sure to read “Read this first!”
- Electric bicycles (Electric Power Assisted Cycles) as used in this manual mean Pedelec.
- Speed pedelec as used in this manual means vehicles with a maximum design speed of more than 25km/h and up to 45 km/h.

ENGLISH

GERMAN

ESPAÑOL

FRANÇAIS

ITALIANO

NEDERLANDS



Read this first!

For Your Safety



To reduce the risk of injury, loss of life, electric shock, fire, malfunction, and damage to equipment or property, always observe the following safety precautions.

Explanation of symbols



The following symbols are used to classify and describe the level of hazard, injury, and property damage caused when the warning is disregarded and improper use is performed.

	DANGER	Denotes a potential hazard that will result in serious injury or death.
	WARNING	Denotes a potential hazard that could result in serious injury or death.
	CAUTION	Denotes a hazard that could result in minor injury or damage to the unit or other equipment.

The following symbols are used to classify and describe the type of instructions to be observed.

	This symbol is used to alert users to a specific operating procedure that must not be performed.
	This symbol is used to alert users to a specific operating procedure that must be followed in order to operate the unit safely.

WARNING

	<p>Do not modify or disassemble the motor unit.</p> <ul style="list-style-type: none"> This may cause damage or overheating, which may lead to fire. Unauthorized opening of the motor unit will void any and all warranty claims.
	<p>Use only a compatible battery</p> <ul style="list-style-type: none"> This may cause damage or overheating, which may lead to fire. If you use any other battery, all compensation claims will become invalid.
	<p>All components mounted to the motor unit and all other components mounted on the electric bicycles (e.g. the chain wheel, crank, rear gear, derailleur, wheels, sprocket) should be replaced only with identical components or components that conform to the electric bicycles.</p> <p>Use the motor unit only for the electric bicycles.</p> <ul style="list-style-type: none"> This may cause injury. Do not use the components for other purposes.

Before starting use

Precautions when riding the electric bicycle

- The electric bicycle have to be used under each country's law.
- Consult your dealer of purchase for assembling or adjusting the product.
- The assist function works only by turning the pedals.
- Motor unit output varies according to the pedalling force.
- Changing the pedalling force also changes the strength (weakness) of the assist function. The strength (weakness) of the assist function changes according to the assist mode.
- The motor unit stops automatically when the speed of the electric bicycle exceeds 25 km/h*.
- The motor unit is automatically reactivated when the speed of the electric bicycle is less than 25 km/h*.
- The motor unit outputs for the duration that the bicycle mark button (Walk assistance) is pressed until the speed of the electric bicycle reaches 5 km/h* (or 6 km/h*), even if the pedals are not turned. (This differs with the settings of each company.)
- The electric bicycle can be ridden as a bicycle without an assist function in the following cases:
 - When the electric bicycle system is turned off
 - When the assist mode is set to [NO ASSIST]
 - When there is no remaining battery power
- If you ride the electric bicycle using an incorrect gear, overheating may occur.
 - * For motor of Speed-pedelec
 - The motor unit stops automatically when the speed of the vehicle exceeds 45 km/h.
 - The motor unit is automatically reactivated when the speed of the vehicle is less than 45 km/h.
 - The motor unit outputs for the duration that the bicycle mark button (Walk assistance) is pressed until the speed of the vehicle reaches 18km/h, even if the pedals are not turned.

Mutual effect of bicycle gears and electric bicycle system







- Use gear shifting in the same way as you would on a regular bicycle.
- By selecting the appropriate gear, speed and distance can be increased by the same pedalling force.

Error codes

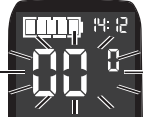
The parts of the electric bicycle system are monitored at all times during use and charging. If an error is detected, an error code will be displayed on the console. To return the console to the standard display, press any button on the operation unit of the console. (In case of Panasonic model)

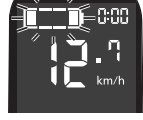
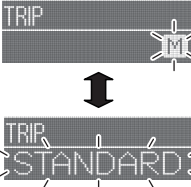
Depending on the error code, motor unit drive is automatically stopped as necessary. The assist function will no longer be activated, though travel can be continued.

When an error is displayed, remedy it according to the remedy described in the following table. Console-related error code

Console*	Description	Remedy
	Torque sensor error • Was the power button pressed while you were pedalling?	Press the power button without pedalling to turn on the power. If this does not remedy the problem, take the electric bicycle to your dealer.
	Speed sensor error • The speed sensor cannot detect the signal correctly.	Turn the power back on again. Check the speed sensor. If this does not remedy the problem, take the electric bicycle to your dealer.
	Battery authentication error • The battery cannot be recognized as an authentic battery (one provided at purchase).	Mount the authentic battery (one provided at purchase).
	Motor unit error • The motor unit is in error.	Take the electric bicycle to your dealer.
	Battery communication error • Communication with the battery is not being performed successfully.	Remove any dirt from the battery terminals. If this does not remedy the problem, take the electric bicycle to your dealer.
	Overheating (motor) • The mode has entered the protection mode since the motor unit is overloaded.	Travel under a lighter load. After a short while, the temperature will return to normal and the assist function will be restored.
	Motor unit error • The motor unit is in error.	Take the electric bicycle to your dealer.
	Is the electric wire connector correctly installed?	Check if the electric wire connector is disconnected. Take the electric bicycle to your dealer.
	Maintenance request • The devices related to Di2 have an error.	Update the firmware and clear any errors of each individual component and the system by connecting the PC and bicycle (system or components) using the PC connected device, and using E-tube Project that is published by SHIMANO INC.

* Above image is for Panasonic standard display.

Daily care

The parts of the electric bicycle system are precision parts and must be cared for daily.

- Prevent all parts of the electric bicycle system from getting dirty. If parts are dirty, wipe off the dirt with a soft, moist cloth. (Battery terminals and corresponding connectors, and terminals on the cradle and on the display unit of the console)
- Do not coat battery terminals with conductive grease since there is the risk of shorting the terminals.
- Before and after use, wipe any dirt or water from the terminals on the console or cradle.
- Do not clean any of the parts including the motor unit with a steam cleaner or high-pressure cleaner.
- Consult only an authorized bicycle dealer for servicing or repair of the electric bicycle.

Specification

The specifications are as follows.

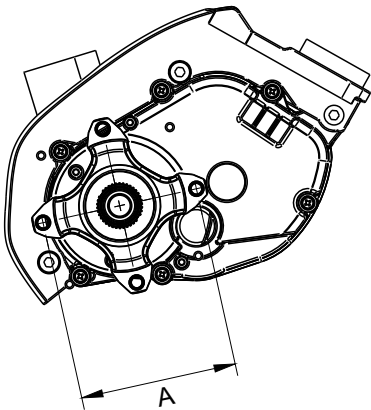

	GX Ultimate unit
Power output	250 W
Rated voltage	36 V DC
Pitch circle (A), spider	104 mm
Crank axle	ISIS
Light output	13.5 V - 1.5 A x 2
Operating temperature	-10 °C to 40 °C
Storage temperature	-20 °C to 50 °C
Weight	Approx. 2.9 kg
Waterproofing level	IPX5

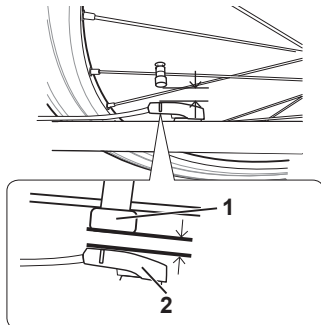

Speed sensor
1: Magnet unit
2: Speed sensor
Before installing the speed sensor, check that the clearance between the speed sensor and the magnet unit will be within 1 to 15 mm. Within the specified reading range (1 mm to 15 mm) of the sensor used Align the speed sensor and magnet unit as shown in the illustration.

After-sales service

Check with an authorized bicycle dealer if you have any questions about the electric bicycle system and its components.

Disposal of Old Equipment and Batteries Only for European Union and countries with recycling systems



These symbols on the products, packaging, and/or accompanying documents mean that used electrical and electronic products and batteries must not be mixed with general household waste.

For proper treatment, recovery and recycling of old products and used batteries, please take them to applicable collection points, in accordance with your national legislation.

End-users in Germany are legally obliged to return used batteries to appropriate collection points. Batteries can be returned to retailers free of charge.

In Spain, users are required to deliver batteries to the appropriate collection points. In all cases, this will be free of charge for users. The cost of environmental management of waste batteries and accumulators is included in the sale price.

By disposing of them correctly, you will help to save valuable resources and prevent any potential negative effects on human health and the environment.

For more information about collection and recycling, please contact your local municipality.

Penalties may be applicable for incorrect disposal of this waste, in accordance with national legislation.



Note for the battery symbol (bottom symbol):

This symbol might be used in combination with a chemical symbol. In this case it complies with the requirement set by the Directive for the chemical involved.

Dealer's Manual

CENTER DRIVING UNIT **GX Ultimate**

with Assembly Instructions

For safety, be sure to read this dealer's manual thoroughly before use, and follow it for correct use.

IMPORTANT NOTICE

•This dealer's manual is intended primarily for use by professional bicycle mechanics.

Users who are not professionally trained for bicycle assembly should not attempt to install the components themselves using the dealer's manuals.

If any part of the information on the manual is unclear to you, do not proceed with the installation. Instead, contact its bicycle manufacturer.

•Make sure to read all instruction manuals included with the product.







WARNING

	Be sure to follow the instructions specified in the dealer's manual when assembling the product <ul style="list-style-type: none">• This may cause injury or accident.
	When performing maintenance work, protect your eyes by wearing safety goggles, or something similar <ul style="list-style-type: none">• This may cause injury.
	Remove the battery and battery charger before carrying out wiring to the bicycle or assembling the bicycle <ul style="list-style-type: none">• This may cause electric shock.



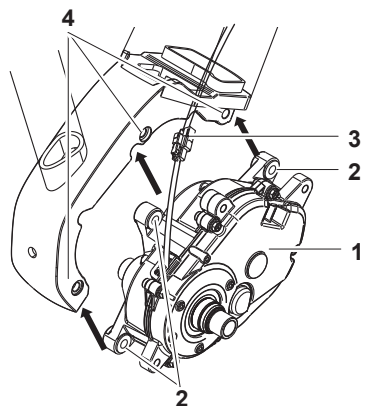
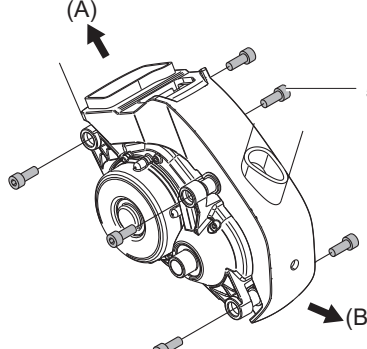
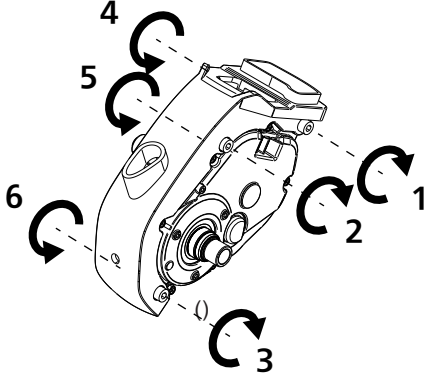

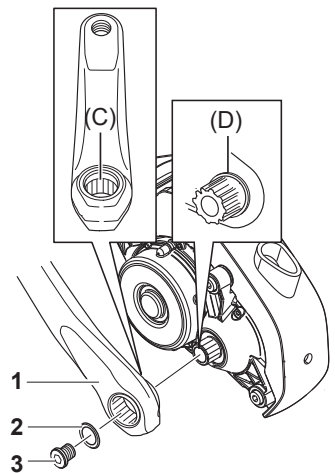
Assembly

Motor unit (front mount)

Install the motor unit after routing the connection cables beforehand.

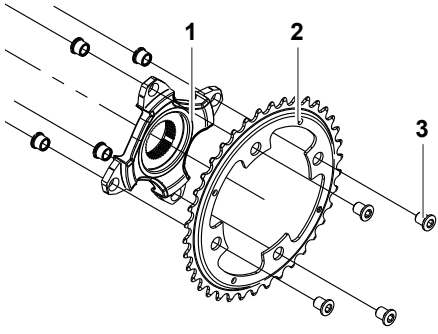
<p>1</p>	<p>After connecting the relay cables at the bicycle side, align the motor unit with the help of the three mounting holes on the right side and left side of the frame. (Make sure the cables are not pinched)</p> <p>Attention</p> <ul style="list-style-type: none"> Do not lift the motor unit with a cable. (It may cause damage) 		<p>1. Motor unit 2. Sleeve (Factory assembled) 3. Relay cable 4. Mounting holes</p>
<p>2</p>	<p>Install (temporarily tighten) the motor unit fixing bolts (M8) on the right side. Thereafter, install (temporarily tighten) the motor unit fixing bolts (M8) on the left side.</p>		<p>5. M8 x L20 (A) Front side (B) Rear side</p>
<p>3</p>	<p>Tighten the motor unit fixing bolts (M8), in a sequence, to the specified torque. (Right side: 1, 2, 3 -> Left side: 4, 5, 6)</p>		<p>6 mm Allen wrench   Tightening torque: 23 N·m</p>
<p>4</p>	<p>Set the left crank on the crank axle.</p> <p>Attention</p> <ul style="list-style-type: none"> Follow the instructions regarding the tightening torque for the bolts used 		<p>1. Left crank 2. Washer 3. Crank screw</p> <p>8 mm Allen wrench   Tightening torque: 30 N·m (reference) (C) (D) ISIS</p>

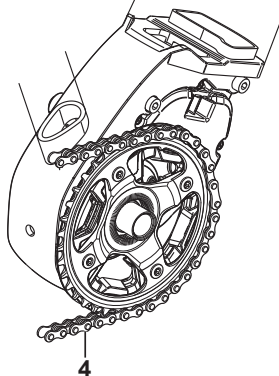
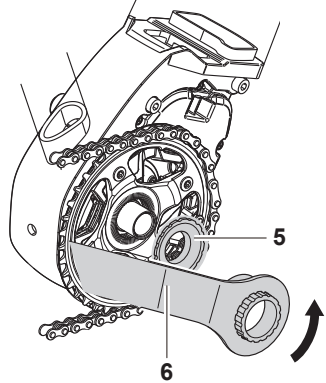
Spider arm

<p>1</p>	<p>Install the chain ring on the spider arm.</p>		<p>1.Spider arm 2.chain ring 3.fixing bolt</p> <p>Shimano TL-FC21 PEG wrench</p>  <p>Tightening torque : 13 N·m</p>
<p>2</p>	<p>Install the chain on the chain ring. Align and insert the wide part of the fixed portion of the front chain ring and the front chain ring notch.</p>		<p>4.chain</p>
<p>3</p>	<p>Install the right crank. Tighten the lock ring by using a dedicated lock ring tool (Shimano TL-UN96). (It has a left-handed thread)</p>		<p>5.Lock ring 6.Lock ring tool</p> <p>Shimano TL-UN96</p>  <p>Tightening torque :40 N·m</p>



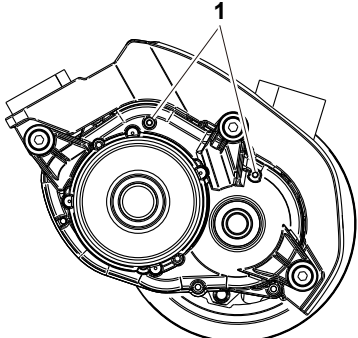

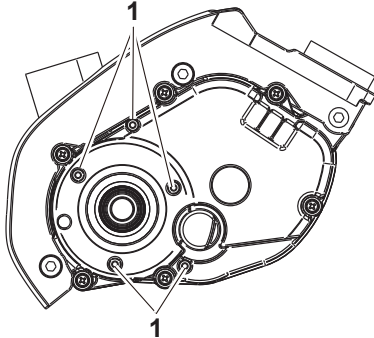

Motor unit left cover

<p>1</p>	<p>Install the motor unit left cover.</p>		<p>1. M4 screws Mounting holes</p>
----------	---	--	--

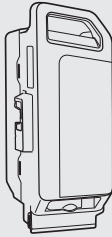
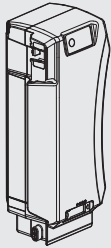
Chain case stay

1	Install the chain case stay.		1. M4 screws Mounting holes
---	------------------------------	--	--------------------------------

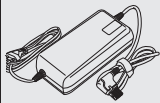
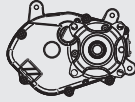
Compatibility

		Center-type battery	New Center-type battery	SIB Battery	Display unit	Operation unit	Battery charger
							
motor unit							
GX Ultimate (Rear mount type)		✓	✓	✗	✓	✓	✓
GX Ultimate (Front mount type)		✗	✗	✓	✓	✓	✓