

# **LEADER FOX**



## Electric Bicycle Operating Instructions

Under the law, the dealer is obliged to attach the LEADER FOX Electric Bicycle Operating Instructions to every product



**E – BIKE** POWER RIDE

**Kent**  
**Braga**





# Introduction

---

Dear users,

Please read carefully all the information regarding your E-LF product to ensure optimal functioning of your e-bike. The following text containing a comprehensive description will provide you with information on all aspects and details (including installation, setting up and general use of the display) regarding the use of our display. This instruction document will also help you solve potential problems and failures.

## What is an electric bicycle?

---

Electric bicycle is a conventional bicycle with an electric drive added to assist the rider. The motor function is actuated by pedalling, which is scanned by a special sensor installed in the pedal hub. Therefore, you have to keep pedalling on an e-bike, the motor is there only to help you. You can set an electric bicycle in motion also using a control button or an accelerator but only up to the maximum permitted speed of 6 KMPH (e.g. for walk assistance). The maximum speed of an e-bike with motor assistance is 25 KMPH, with a 10% tolerance (when this speed limit is reached, the motor switches off and you need to pedal just like with a regular bicycle). When your battery runs out of power or your motor is off, you can ride your electric bicycle as a conventional bike, without any resistance at all.

From the point of view of the Road Traffic Act, an electric bicycle whose features conform to European standard EN 15194-1 is regarded as a regular bicycle, i.e. you can ride on bike trails, do not need a driver's license and a helmet is mandatory only up to 18 years of age.

## Description

Intelligent display with control



## Factors influencing the electric bicycle range

- 1. Rolling resistance of the tyres.** Leader Fox e-bikes are fitted with tyres with low rolling resistance and increased resistance to puncture. It is also important that the tyres are inflated properly. Therefore, if the tyres of your electric bicycle are underinflated, the range will decrease.
- 2. Weight of the electric bicycle.** The lower weight of the electric bicycle, the greater the range.
- 3. Battery status.** It depends on whether the battery was fully charged before your trip. It is also to be expected that the higher the number of discharge cycles the battery has undergone, the smaller capacity it has.
- 4. Profile and surface of the track.** The higher the elevation difference and the steeper hills you negotiate and the worse surface, the shorter the range.
- 5. Riding mode.** It depends on which of the three riding modes you have set.
- 6. Continuity of riding.** The more braking and acceleration, the shorter the range.
- 7. Air resistance.** For example, it depends on whether we ride a bicycle with low frame and sitting upright or whether we ride sporty bicycle with seat set to the same height as the handlebars.
- 8. Wind strength.** The stronger the wind we have back, the longer the range and vice versa.
- 9. Weight of the rider and load.** The greater the weight, the shorter the range.
- 10. External temperature.** The lower the temperature, the less battery capacity can be used while riding.

# Electric set

## M500

The system uses monitoring of torque, monitoring of speed of the pedal assist system and monitoring of real speed of wheels.

The system uses a dual protection feedback for measuring the speed signal to ensure safety and reliability of the system.

It has high starting torque, maximum torque of over 95 Nm, suitable especially for riding uphill.

It is highly efficient with low power consumption, long range, low noise levels, and smooth operation.

### **Description and scope of operation:**

The motor unit works properly under the following operating conditions:

Temperature range - 20 + 55°C

Relative humidity - 15 – 95% RH

Maximum torque -  $\geq 95$

Weight - 3.3Kg

Noise - <55 dB

Dustproof/ waterproof - IP66

Certified - CE ROHS/ EN14766/ EN114764/ REACH

### **Description of the power unit is placed on the cover and shows the following information:**

MM G522.250 15 033 F5 S329 0001

MM – Mid motor

G520 – Engine model

250 – Rated engine power

15 – Number of winding turns

033 – Connection combination sort

F5 – Measurement and control equipment number

S329 – Date of manufacture, indicating it is manufactured on March 29, 2018

0001 – Production serial number, ranging from 0000 to 9999, 0001 is the production serial number of the first motor

**Dimensions of the power unit:**

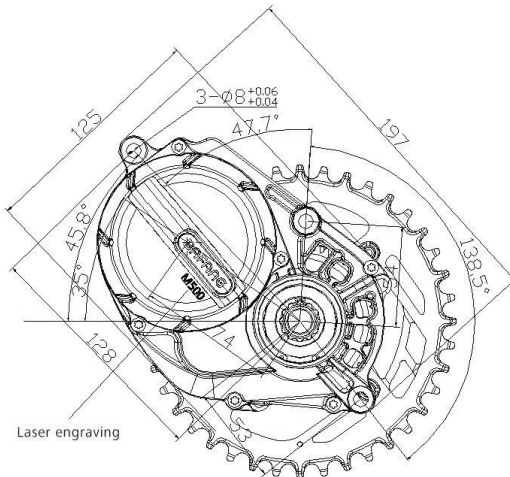
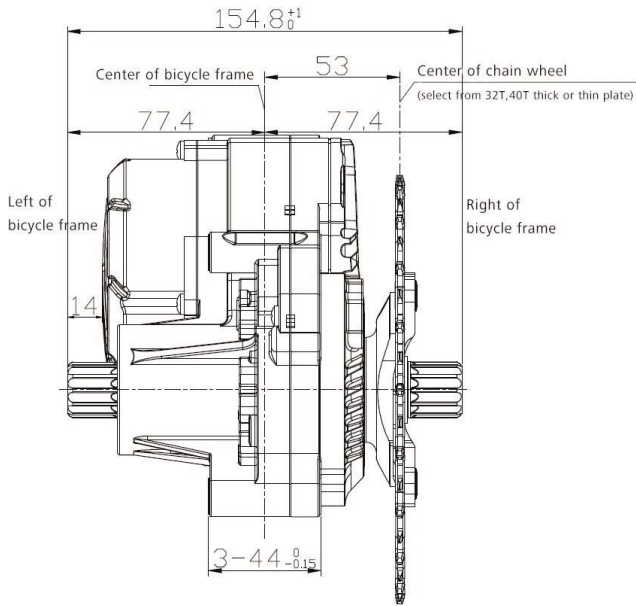

# Safety instruction

## Battery:

- Do not throw the battery into fire.
- Do not throw the battery into water.
- Do not use the battery for other appliances. It has been made specifically for this model.
- Do not dismantle or modify the battery.
- Do not connect the positive and negative poles of the battery.

## Charger:

- Do not dismantle or modify the charger.
- Do not use the charger for other appliances. It has been made specifically for this model.
- Do not throw the charger into fire or water.
- Do not touch the charger with wet hands.
- Keep the charger from animals or children.
- Do not cover the charger.
- Do not use the charger if it is broken

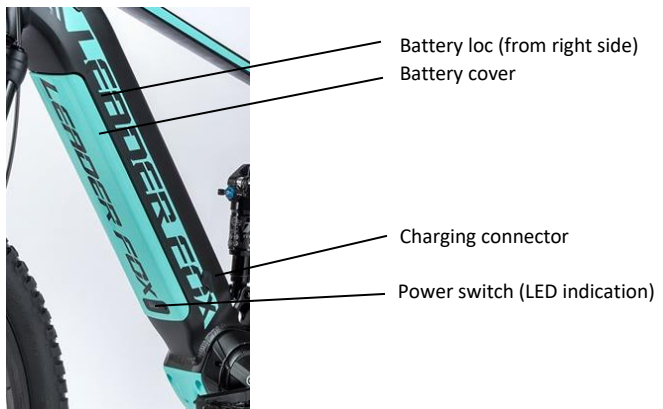

## Charging set



# Battery

## **Battery charging and maintenance:**

Charge the battery in a dry environment to avoid short-circuit damage.

Charge the battery to at least 60% of the capacity once every 3 months even when the bicycle is not used.

Do not cover the battery or the charger.

Do not leave the battery constantly connected to the power source.

Do not use the battery for other appliances. It has been made specifically for this model.

Do not disassemble or modify the battery pack.

Do not throw the battery into fire or expose it to extreme temperatures.

Recharging time from zero to 100% is 1-7 hours.

## **Drive warranty:**

The warranty applies to those drive parts that are not sensitive to improper handling (pack, electronics, charger, etc.); such parts are covered by a 24-month warranty.

The warranty does not apply to chemical parts of the battery and to capacity reduction due to normal use (39% after the expiry of two years); those parts are covered by a 12-month warranty.

## **Charging:**

The battery is the most expensive part of an electric bicycle; therefore, pay increased attention during handling, charging and storage. The battery is sensitive to precise charging. Therefore, it is necessary to charge Li-Ion rechargeable batteries using only a charger supplied by us. Connect the charger to 220-240 V power outlet. 5A protected circuit is sufficient. The charger will automatically suspend charging when full capacity of all cells is reached.

We recommend discharging the battery in full after each ride to ensure that your battery will be up to its full capacity for your next ride. Charging the battery may last 1 to 5 hours depending on the condition of the battery cells. Charge it exclusively in covered dry areas (moisture and dripping water can damage the charger) at a temperature of 5 to 40°C.

The charging process is indicated by a red glowing LED. It will turn green when the battery is charged and the charging process is complete. The battery contains a charge-monitoring indicator (when the charge indicator button is pressed, the light indicator will come on). Always switch off the battery when finished riding the bike.

## **Normal battery behaviour:**

If the motor stops running smoothly and switches to intermittent operation, it could be a sign of low battery capacity. In that case switch off the electric drive system and continue without motor assistance, as if riding a conventional bicycle.

Battery warming is normal and does not indicate any defect. The battery is protected by a temperature sensor and switches off automatically in case of excessive overheating. Wait until the battery cools down to its normal operating temperature and then ride on.

If you feel your total battery capacity has dropped, it could be caused by charging or operation in suboptimal climatic conditions. Carry out 3 full charging cycles. Fully discharge the battery while riding and then charge to its full capacity at room temperature.



If the charge indicator shows that the battery is discharged, there is still a minimum voltage level in it which protects it against damage but is not enough to power the electric bicycle. Recharge the battery as soon as possible. Never leave the battery fully discharged, it could result in its damage.

In the case, that the battery will be turned on more than 30 min and bike will not be used, the battery will be automatically switched off.

**Proper care of the battery prolongs its life.**

# LCD display

## Product:

Intelligent display DP C240.CAN

## Supplier:

Bafang

## Electrical parameters:

Battery supply 36V

Rated operating current 12mA

Off leakage current < 1 uA

CAN BUS protocol

Maxoutput current 30mA

Maxoutput current to controller 50mA

Operating temperature – 20 ~ 45 °C

Storage temperature – 30 ~ 70 °C

## LCD dimensions and materials:

Product shell is ABS, transparent window is made with high strength Acrylic.

Can be used up to -20°C.

CE / IP65 water proof / ROHS.



**LCD Display description:**

Threebutton console which is with BOOST mode is more user-friendly.

Speed indication: Includes maximum speed, average speed.

Unit switch between imperial and metric.

Intelligent battery capacity indication.

Control and indication for the headlight.

5 levels of backlight brightness setting.

Indication for power assistance level with 6 levels: 0/1/2/3/4/5.

Indication for trip: To indicate single-trip distance, total distance and remaining distance.

Multiple data indication: Indication for the remaining distance, Indication for the consumption of energy CALORIES. (Note: If the display has this function.)

Record and indication for the error information.

Button with feedback of haptic vibration.

Control and indication for push assistance.

Parameters resettable with BESST BOX.

USB charging port:  $\leq 5V$ ,  $\leq 1A$ .

Dual Bluetooth integrated.

**Maximal range:**

Maximal range is set with fully charge battery and flat terrain and little bit of headwind. Average range is calculated with ideal set of the assist and slightly hilly terrain.

# Assembly instructions

## Display assembly:

Please pay attention to the tightening torque of screws. Damage caused by excessive tightening torque or incorrect assembly / disassembly is not covered by warranty.



Up

Down

Boost / On-Off



# Control

## Turning on the electrical system of the e-bike

Before switch on of the system please check electrical wiring.

Switch on power of the electrical system on battery, colored backlighting illuminates.

Switch on display with press and short hold (1,5 second) "ON/OFF" button. Display will automatically turns off if it is not used for a while.

After ride turns off e-bike in the same way.

For better gear change is appropriately stop pedaling for a while.

Before ride please lock battery in frame **and take out the keys.**

## Assist level operating

Short press "UP/DOWN" button can change the assist level. 0 is without assistance. 5 is the highest level of assistance.



## Walking mode

Press and hold DOWN button for 2 second can get into walking mode, out of the mode when release the button.

Walk assistance speed depends on gear ratio. Lower gear ratio / slower speed, higher gear ratio/ faster speed.



## Speed and mileage mode switch

Briefly press "BOOST" button to switch to different data interfaces, then circularly to show single trip distance (Trip,km) → total distance (ODO,km) → maximum speed (MAX,km/h) → average speed (AVG,km/h) → remaining distance (RANGE,km) → energy consumption (CALORIES/CAL,KCal) → riding time (TIME,min) → real-time output power (POWER,w).



## Battery capacity indication:

The battery remaining capacity will be indicated as the exact percentage, in addition, the frame of the symbol will flash at 1Hz when capacity is less than 5%, means the battery needs to be charged.

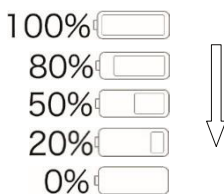

## Headlight/Backlight On/Off

Press and hold "+" to turn on the display backlight as well as headlight, this moment you will see the symbol of headlight in the screen; On the contrary, press and hold "+" again to turn off the display backlight and the headlight (If the display is turned on in a dark environment, the display backlight/ headlight are turned off manually, they also need to be turned on manually afterwards).

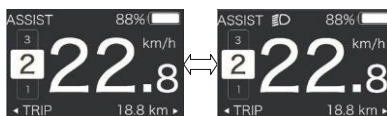

**Bluetooth connection:**

This display has Bluetooth module integrated and connectable to BAFANG's own smart phone application "BAFANG GO". In addition, the SDK is open for customer to develop APP individually.

This display is also connectable to the chest belt and catch real-time heart beat data from the chest belt and display it and send the data to smart phone.

The list of data transmit from display to smartphone as below:

Item	Data
1	Speed
2	Capacity
3	Support level
4	Data of battery
5	Output of sensors
6	Remaining range
7	Calory
8	Component info.
9	Current
10	Heart beat
11	Trip
12	ODO
13	Headlight status
14	Error code

## Parameter setting

Press and hold “+” & “-” button synchronously to enter into Display Setting interface, and briefly press “+” or “-” to switch to from “Setting” to “EXIT” and then briefly press “ON/OFF” button to confirm the operation.

### Unit (Km/mile):

Briefly press “+” or “-” to go to “UNIT”, and then briefly press “ON/OFF” to switch between “Metric”/ “Imperial”, then briefly press “ON/OFF” to confirm selection and save the setting and exit back to the “UNIT”. Press and hold “+” and “-” synchronously to save and exit back to the main interface or you can also select “BACK” → “EXIT” to exit back to the main interface.

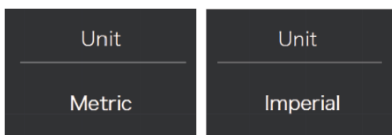

### Auto Off

Briefly press “+” or “-” to go to “Auto Off”, and then briefly press “ON/OFF” to select among “OFF”/“9”/“8”/“7”/“6”/“5”/“4”/“3”/“2”/“1” ten levels, then briefly press “ON/OFF” to confirm selection and save the setting and exit back to the “Auto Off”. Press and hold “+” and “-” synchronously to save and exit back to the main interface, or you can also select “BACK” → “EXIT” to exit back to the main interface.

Notice: “OFF” means this function is off, the unit is minute.

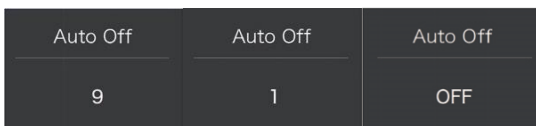



### Brightness setting

Briefly press “+” or “-” to go to “Brightness”, and then briefly press “ON/OFF” to select among “100%”/“75%”/“50%”/“30%”/“10%”

five levels, then briefly press “ON/OFF” to confirm selection and save the setting and exit back to the “Brightness”. Press and hold “+” and “-” synchronously to save and exit back to the main interface, or you can also select “BACK” → “EXIT” to exit back to the main interface.

Notice: “10%” is the weakest brightness and 100%” is the strongest brightness.

Brightness	Brightness	Brightness
100%	75%	50%
Brightness	Brightness	
10%	30%	

### Indication switch of output with current or power

Briefly press “+” or “-” to go to “Power View”, and then briefly press “ON/OFF”, then briefly press “+” or “-” to switch between Power and Current, then briefly press “ON/OFF” to confirm selection and save the setting and exit back to the “Power View”. Press and hold “+” and “-” synchronously to save and exit back to the main interface or you can also select “BACK” → “EXIT” to exit back to the main interface.

Power View	Power View
Current	Power

### Light sensitivity setting

Briefly press “+” or “-” to go to “Sensitivity”, and then briefly press “ON/OFF” to select among “0”/“1”/“2”/“3”/“4”/“5” five levels, then briefly press “ON/OFF” to confirm selection and save the setting and exit back to the “Sensitivity”. Press and hold “+” and “-” synchronously to save and exit back to the main interface, or you can also select “BACK” → “EXIT” to exit back to the main interface.

Notice: “0” means light sensor is off. Level 1 is the weakest sensitivity and level 5 is the strongest sensitivity.

AL Sensitivity	AL Sensitivity
5	1
AL Sensitivity	AL Sensitivity
0	OFF

### Trip reset - to clear the single trip distance

Briefly press “+” or “-” to go to “TRIP Reset”, and then briefly press “ON/OFF” to switch between “NO”/“YES” (“YES”- to clear, “NO”no operation), then briefly press “ON/OFF” to confirm selection; After confirmation, briefly press “ON/OFF” again to save the setting and exit back to the “TRIP Reset”. Press and hold “+” and “-” synchronously to save and exit back to the main interface, or you can also select “BACK” → “EXIT”to exit back to the main interface.

Notice: The riding time (TIME), average speed (AVG) and maximum speed (MAXS) will be reset simultaneously when you reset TRIP.

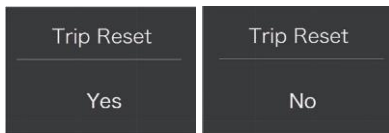

### Vibration setting

Briefly press “+” or “-” to go to “Vibration”, and then briefly press “ON/OFF” to select between ON and OFF (ON means vibration button is on; OFF means vibration button is off), then briefly press “ON/OFF” to confirm selection and save the setting and exit back to the “Vibration”. Press and hold “+” and “-” synchronously to save and exit back to the main interface, or you can also select “BACK” → “EXIT” to exit back to the main interface.



### Speed limit information:

This value is preset at 25 km/h by law.

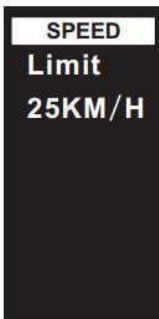

### Battery information:

Bttery status information

```
BATTERY
BAT %:
    0%
BAT V:
    38.2V
Charge:
    112
```

**Auto Off:**

Press UP/DOWN button to change the auto power off time, from 1 to 10 the number represent time (minutes) to shutdown, default value is 5 minutes.

```
AUTO OFF
1 Min
2 Min
3 Min
[ 5 Min]
8 Min
10 Min
```

**System Info:**

System status

```
INFO
S/N :
C117001A
0010001
FW Ver:
V1.0
HW Ver:
V1.0
```

### Reset:

For choosing Yes/No use Up/Down buttons and for confirmation press "M" button. Yes mean the data are resets.

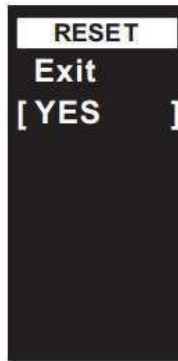

### Data clearance:

By long press M button for 3 seconds enter to the Data clearance. For choosing Yes/No use Up/Down buttons and for confirmation press "M" button. Yes mean the data Trip, Trip time, AVG are clean.

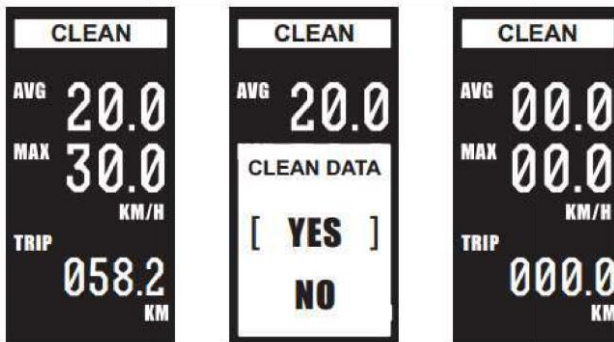

### Basic setting:

System is factory set. For changing these parameters contact your dealer or producer.  
Do not change these parameters by yourself, you can damage the e-bike.

Damaged caused by improper treatment is not within the scope of the warranty.

# Maintenance

## Regular maintenance:

- maintain all components of the electric bicycle clean
- use only the recommended and tested cleaning materials
- regularly lubricate the chain with suitable oils
- in winter, clean the electric bicycle after each ride and pay increased attention to removing salt from battery contacts and other connectors
- while handling the electric bicycle, make sure the cables of the electric system are not damaged. Damaged cables pose a risk of electric shock
- regularly check all connections for correct tightening and brakes for correct function. Check also individual parts of the electric bicycle for damage. For example: cracks on the frame, fork, handlebars, stem, damage to cables, damage to battery pack, etc.

## Battery transport:

Battery transport is subject to the requirements of regulations on dangerous goods. Private users may transport undamaged batteries on roads without having to conform to other conditions.

In case of transport by commercial users or by third parties it is necessary to comply with special packaging and marking requirements (e.g. ADR regulations)

Batteries should only be sent if the battery pack is undamaged. Plug loose contacts and pack the battery to prevent its movement in the packaging. Notify the forwarding service that the transport concerns dangerous goods.

## Battery storage:

Store the battery in a dry and well-ventilated place, out of reach of direct sunlight and other heat sources. In case of cold storage it is necessary to let the battery warm up to normal room temperature (20°C) before putting into operation.

Never leave the battery fully discharged. It could result in its permanent damage. For long-term storage keep the battery fully charged. However, do not store it while permanently connected to the charger or installed in the electric bicycle.

Li-Ion batteries are fully recyclable. After expiry of the battery life you can return it at any collection point or your dealer.

If you use an e-bike in hard conditions (long-term use of the maximum assistance), for longer ride at higher temperatures (30 ° C or above), in direct sunlight or when the battery is partially discharged and a combination of these situations is it possible that bike will automatically switch off. This is a fuse protecting the control unit against burning. We recommend stop the ride and let the bike (control unit) cool down little bit. This is not a defect.

# Possible problems and their solutions

In case of system failure perform its diagnostics or contact your dealer.

## **The control LCD display is not on:**

- always make sure the battery is charged
- check whether the battery is inserted correctly, whether the battery switch is on
- check the connections of the control unit and the display

## **The motor does not start when the walk assistance button is pressed**

- check the connection of the motor cable (at the motor and the control unit)
- check the connections of the control unit and the display

## **The motor does not start when rotating the pedal cranks (pedalling)**

- check the connection of the pedalling sensor to the control unit
- check the distance between the pedalling sensor and the magnet disk (max. 4 mm)
- check whether the disk is firmly attached to the central axle and does not spin freely
- in case of use of compact-type pedalling sensor

# Warning

When there is a problem with the electric bicycle, it can show error messages. LCD display will show the icon and an error code will be displayed on the speed display. Error codes are marked from 01 E~FF E; see their meaning in the table below.

Error code	Description	Solution
6	Low battery voltage	Check battery voltage
7	High voltage protection	Check battery voltage
8	Hall probe error	Check motor
9	Three-phase supply error	Check motor
11	Overheating controller sensor	Check controller
12	Overvoltage controller sensor	Check controller
13	Overheated battery	Chcek battery
21	Speed sensor error	Check the position of the sensor
22	BMS communication error	Change battery
30	Communication error	Check connectors

# Electric set warranty

## **Complaint procedure:**

Submit any complaints concerning the electric set or the battery to your dealer.

When filing a complaint, submit a proof of purchase and a warranty certificate with the registered serial number of the battery and indicate the reason for the complaint and a description of the defect.

## **Warranty conditions:**

24 months for electric bicycle components – applies to manufacturing and material defects beyond normal wear and tear caused by use.

12 months for battery life – the nominal battery capacity does not drop below 70% of the total capacity over 12 months from the sale of the electric bicycle.

## **Warranty conditions:**

The electric set must be used exclusively for the purposes it is intended for.

The electric set must be used, stored and maintained in accordance with these Operating Instructions.

## **A warranty claim shall expire:**

If it is found out that the damage to the product is due to the user's fault (accident, inexpert handling beyond the framework of these Operating Instructions, tampering with the structure of the electric bicycle or connection of the electric system, improper storage, etc.).

Expiry of the warranty period.

**The warranty only applies to the first owner**



## Recommended tire pressure for FATBIKE

CST BFT 26 "x 4" for riding on paved roads – 0,7-0,8 bar



# Warning

If you do not understand any of the points in these Operating Instructions, please contact the dealer for explanation. Please read the whole manual!

Do not lend the e-bike to persons not briefed in its use and operation. Complaints resulting from improper handling will not be accepted.

The LF Energy electric bicycle is not intended for use by children under 15 years of age. Likewise, the electric bicycle cannot be used by persons unable to pedal or handle it independently. The manufacturer is not to be held responsible for any potential injuries or damage to the bicycle!

Ideal weather conditions for using an electric bicycle are dry days, when the outdoor temperature is above 10°C. When used at lower temperatures, the battery discharges faster due to physical phenomena. Using the electric bicycle at temperatures below 0°C is not recommended.

Do not expose the bicycle to direct sunlight as it is fitted with a protective temperature sensor for the electric motor.

Never submerge the battery, the charger and other electric components in water or another liquid.

Never wash the electric bicycle in a pressure washer (WAP) and always remove the battery before washing

It is forbidden to tamper with the connections of the electric motor, the control unit and the battery. Violating this section may result in the warranty not being acknowledged or in irreversible damage to the electric bicycle.

DO NOT USE chargers and components other than the ones included with the electric bicycle.

We cannot be held responsible for damage caused by use of other non-approved goods

# bohemia**bike**

b i k e f a c t o r y

Na Pankráci 1724, 140 00 Praha 4 - Pankrác, IČ: 63910756

## EU PROHLÁŠENÍ O SHODĚ

Prohlašujeme, že elektrokola značky Leader fox, dodávané na český i zahraniční trh společností Bohemia bike a.s. jsou v souladu s platnými českými technickými normami ČSN EN ISO 4210-2 i ustanovením evropských směrnic EN 15194:2017, 2006/42/EC A 2014/30/EU pro jízdní kola s pomocným elektrickým motorem tzv. EPAC. Výrobky jsou v souladu se směrnicí na strojní zařízení 2006/42/ES (NV 176/2008 Sb.) Tato vyrobená strojní zařízení splňují všechna příslušná ustanovení předmětného předpisu EU.

Seznam výrobků obsahuje příloha dokumentu:

V Českých Budějovicích 1. ledna 2020

**bohemia bike a.s.**

IČ: 63910756, DIČ: CZ63910756  
Na Pankráci 1724, 140 00 Praha 4 - Pankrác  
CZECH REPUBLIC (8)

.....  
Pavel Müller, předseda představenstva a odpovědná osoba za veškerou tech. dokumentaci

# **LEADER FOX**



Enjoy many pleasant and safe kilometres on your new electric bicycle.

## **Your Leader Fox Team**



**Czech brand of electric bicycles.  
BOHEMIA BIKE**

**Address**

Na Pankráci 1724  
14000 Praha 4 - Pankrác

**Development, design and manufacturing**

Okružní 697  
České Budějovice 37001

Phone: 388 314 885  
Email: [info@leaderfox.cz](mailto:info@leaderfox.cz)

